



SV17

Mini-excavator



SV17

Operating weight : 1790/1670 kg

Arm digging force : 755 kgf

Bucket digging force : 1550 kgf

The SV17 create in the class of 1,5 new Semi-



Mini-excavator



*s a new standard
00-kg excavators :
ViO series*



SV17



Compactness

*The Semi-Vio series
makes an impact in
For the first time, a 1.5-ton
combines compactness with
high performance level*

Design principles

- Compact dimensions :
 - width of the machine reduced to 980 mm ;
 - rear swing radius : 980 mm ;
 - front swing radius with boom swing : 1340 mm.
- Weight and dimensions allowing easy transport on a trailer or in an utility vehicle.



SV17



Advantages for the user

- Possibility to work in narrow areas, where a conventional machine of 1500 kg is not able to work.
- Maximum superb all-round visibility : safety and productivity for the operator.
- Particularly well-suited to work in urban areas : cable-laying, landscaping...
- Loading and easy transfer from one site to another : more productivity.

Mini-excavator



YANMAR

ies from Yanmar
n this weight class.
500 kg mini-excavator
act dimensions,
ls and great stability.

Comfort and safety

Spacious and ergonomic pilot system

- Perfect position of joysticks, armrests and travel levers with pedals.
- Separate pedals for using the auxiliary power take-off line and boom offset.
- Comfortable, multi-adjustable seat.
- Access possible from both sides on the canopy version.



Spacious cabin

- Cabin with a lot of space for such a compact machine.
- Wide access to the operating position.
- Defroster, heater, ventilation, inside lighting, windscreen washer.



Maximum operator safety

- Canopy and cabin meet the requirements of the strictest safety standards :
 - ROPS (Roll Over Protective Structure) ;
 - FOPS 1 (Falling Object Protective Structure) ;
 - TOPS (Tip-Over Protective Structure).
- Large safety lever on access to control position : in the raised position it prevents all working movements and travel.
- The really designed boom enables perfect visibility to the bottom of the trench.



ies from Yanmar
n this weight class.
500 kg mini-excavator
act dimensions,
Is and great stability.



High performance

Hydraulic circuit Load-Sensing. Variable flow piston pump.

- Precise working movements.
- Simultaneous operations.
- Safety and productivity, particularly for operations requiring accuracy : grading.



Dual or single-action auxiliary circuit fitted to arm end.



Reliability and a

Robust construction

- Machine constructed using modular assemblies : easy and reliable assembly of all components.
- Upper frame made from a single casting providing improved stability and greater durability.
- Rear and side bonnets in steel.
- Perfect protection on boom and blade cylinders.
- Integrated working lamp.



A new-generation Yanmar "TNV" (Totally New Value) engine

- Improvement and modernisation of TNE series, which is already well-known for its "clean and quiet" profile :
 - reduced emissions for an even cleaner engine ;
 - noise reduction for an even quieter engine ;
 - improved starting (warms up faster).
- The new TNV series exceeds the most stringent emissions standards.

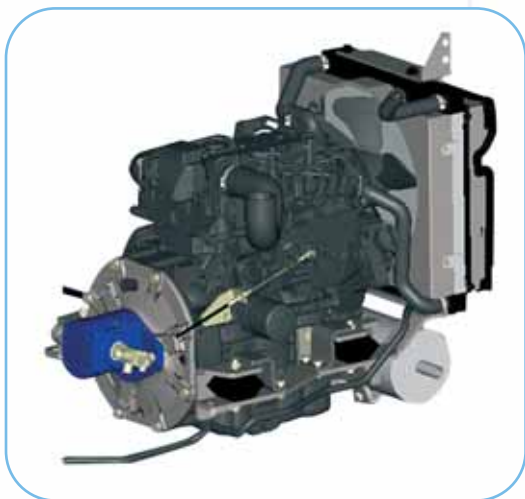

Successful combination between the engine and the hydraulic system

- Reduced fuel consumption.
- Increased productivity.
- Less exhaust fumes.

Excellent traction forces for an excavator in this weight class.

2nd speed command.

tank refuelling



Accessibility

Easy access to all maintenance points : significant decrease in service times and operational costs

- Large rear bonnet :
 - Direct access to fuel, air, hydraulic return filters and coolant expansion tank.
- Opening of the front seat plate :
 - Immediate access to battery, alternator, starter motor, PTO selector valve and electrical components.
- Removing of the right hand side panel :
 - Immediate access to fuel tank and radiators.
- Removing of the left hand side panel :
 - Direct access to hydraulic pump and suction filter.
- Quick access to the control valve by removing the left side panel and the floor plate.



TECHNICAL SPECI

Engine

Yanmar Diesel 3 cylinders	3TNV70-VBVA
Rated Output (DIN 6270B)	9.5 kw/12.9 HP/2100 rpm
Displacement	854 cm ³
Max. torque	51.4 N.m./1500 rpm

Load-Sensing hydraulic circuit

System capacity	24.5 l	Straight travelling	
Hydraulic tank capacity	16 l	Direct return to hydraulic tank	
Max. pressure	200bar	Accumulator	
Variable flow piston pump	37.8 l/mn		

Performances

Travelling speed	2.0/3.5 km/h	Gradeability	30°
Swing speed	9.4 rpm	Shoe width	230 mm
Digging force (arm/bucket)	755/1550 kgf	Ground clearance	190 mm
Boom swing (L/R)	40°/80°	Blade (width x height)	980 x 230 mm
Ground pressure*	0.29/0.28 kg/cm ²		* cabin/canopy



Miscellaneous

Fuel tank	24.5 l
Cooling system	2.9 l
Transport dimensions (L x w x h)	3660 x 980 x 2256 mm
Noise level LwA (2000/14/EC & 2005/88/EC)	93 dBA



Optional equipment

Special paint	2 additional working lights
Bio Oil	Right hand side rear view mirror
Safety device for loading	Left hand side rear view mirror
Anti-theft device	Rear mounted mirror
Long arm (+ 200 mm)	Cup holder / bottle holder (Cab)

PTO	Theoretical data	
	Pressure	2100 rpm
	0 ~ 196 bar	37.8 ~ 17.5 l/mn
	0 ~ 196 bar	37.8 ~ 17.5 l/mn



- The output reduces as the pressure increases.



Operating weight (EC Norm) +-2% :

1790/1670 kg (cabin/canopy)

Transport weight +-2% :

1715/1595 kg (cabin/canopy)

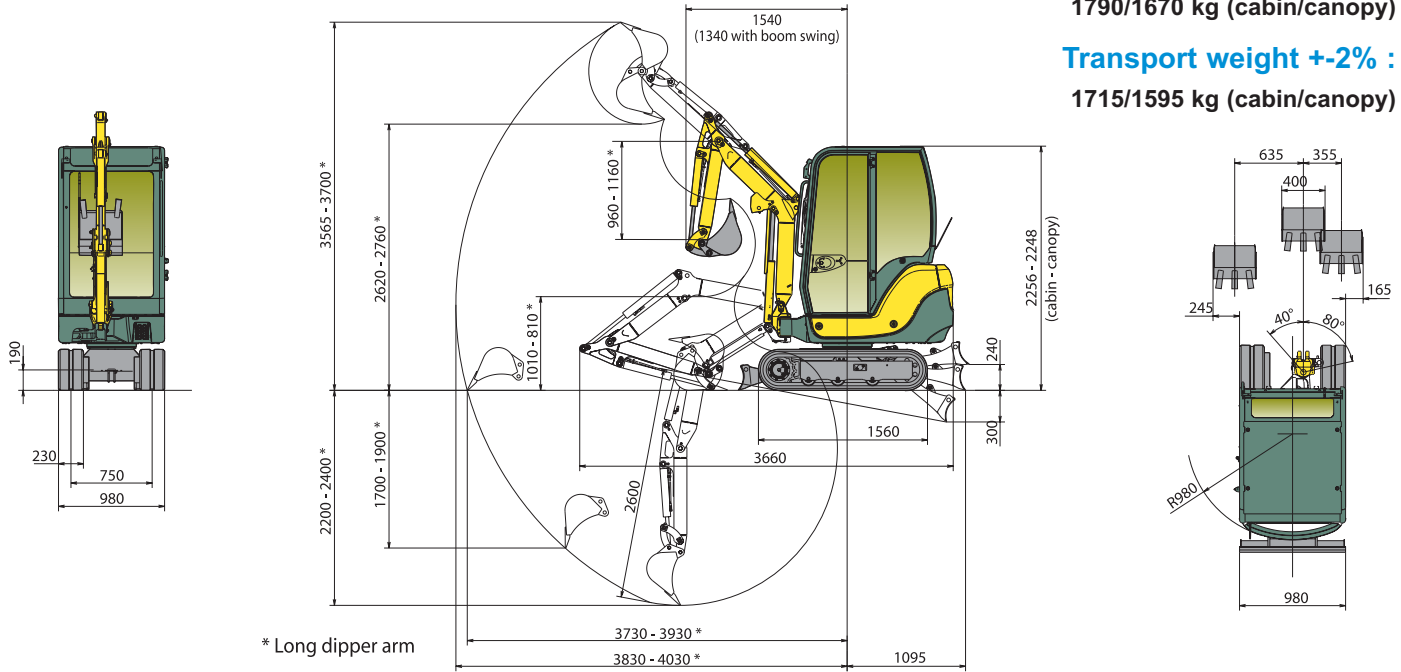

Blade on ground

A	Maxi		3.0 m		2.5 m		2.0 m	
B								
3.0	*290	*300	-	-	-	-	-	-
2.5	205	*290	-	-	-	-	-	-
2.0	180	*295	205	*270	-	-	-	-
1.5	160	*290	200	*290	*295	*300	-	-
1.0	155	*300	200	*320	255	*370	350	*465
0.5	155	*310	190	*350	250	*430	340	*585
0	160	*325	195	*385	245	*480	315	*645
-0.5	170	*340	190	*390	245	*500	320	*675
-1.0	200	*350	-	-	240	*475	320	*620
-1.5	250	*355	-	-	-	-	335	*540

Blade above ground

A	Maxi		3.0 m		2.5 m		2.0 m	
B								
3.0	*290	*300	-	-	-	-	-	-
2.5	200	*290	-	-	-	-	-	-
2.0	170	*295	200	*270	-	-	-	-
1.5	155	230	195	*290	*295	*300	-	-
1.0	145	210	185	*320	250	*370	350	*465
0.5	150	215	185	265	240	350	320	480
0	155	220	185	260	230	330	300	455
-0.5	165	240	185	275	235	335	305	470
-1.0	190	270	-	-	230	330	300	425
-1.5	240	*350	-	-	-	-	315	*540

Subject to any technical modifications.
Dimensions given in mm with standard Yanmar bucket.

Machine with canopy,
long dipper arm,
rubber crawlers,
bucket of 38 kg (400 mm).

- A : Overhang from rotational axis (m).
- B : Height of hooking point (m).
- C : Safe working load (kg).
(+4% with cabin).

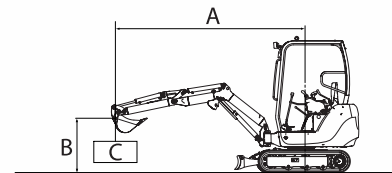

Tipping load,
rating over front

Tipping load,
rating over side 90°

The data contained in these tables represent the lifting capacity in accordance with ISO standard 10567. They correspond to 75% of the maximum static tipping load or 87% of the hydraulic lifting power. Data marked * are the hydraulic limits of the lifting power.



AMMANN-YANMAR SAS

25, rue de la Tambourine - F-52100 SAINT DIZIER

sales@ammann-yanmar.fr

www.ammann-yanmar.com



Venus Studio - Printed in France - Materials and specifications are subject to change from the manufacturer without notice. Please contact your local Ammann-Yanmar dealer for further information.